

Series MT

Orange loading grab



MT4.1-5 (with DWP-15)

Excavator weight class (t): 30-55

Operating pressure (bar): 350 grabbing / 140 slewing

Load bearing capacity (t): Grab:8 / Slewing gear: 15

Speed (rpm): 15

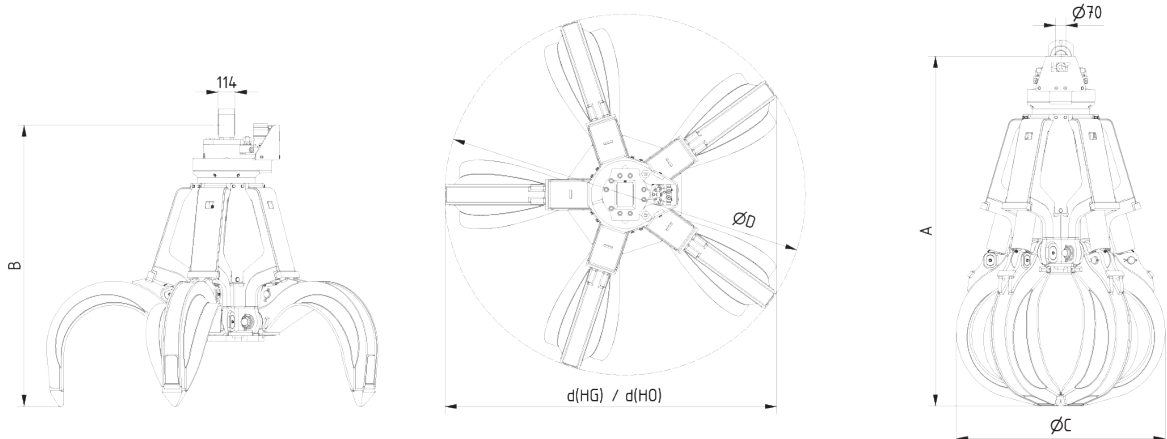

| Type | Capacity (l) | Weight (kg) | | Dimensions (mm) | | | | | |
|-------------|--------------|-------------|------|-----------------|------|------|------|-------|-------|
| | | HO | HG | A | B | C | D | d(HO) | d(HG) |
| MT4.1-400-5 | 400 | 1940 | 2005 | 2168 | 1799 | 1350 | 2160 | 1972 | 2017 |
| MT4.1-600-5 | 600 | 1943 | 2020 | 2288 | 1840 | 1400 | 2360 | 2172 | 2217 |
| MT4.1-800-5 | 800 | 2001 | 2120 | 2437 | 1891 | 1470 | 2640 | 2425 | 2468 |



Half open (HO)

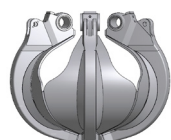

Half closed (HG)

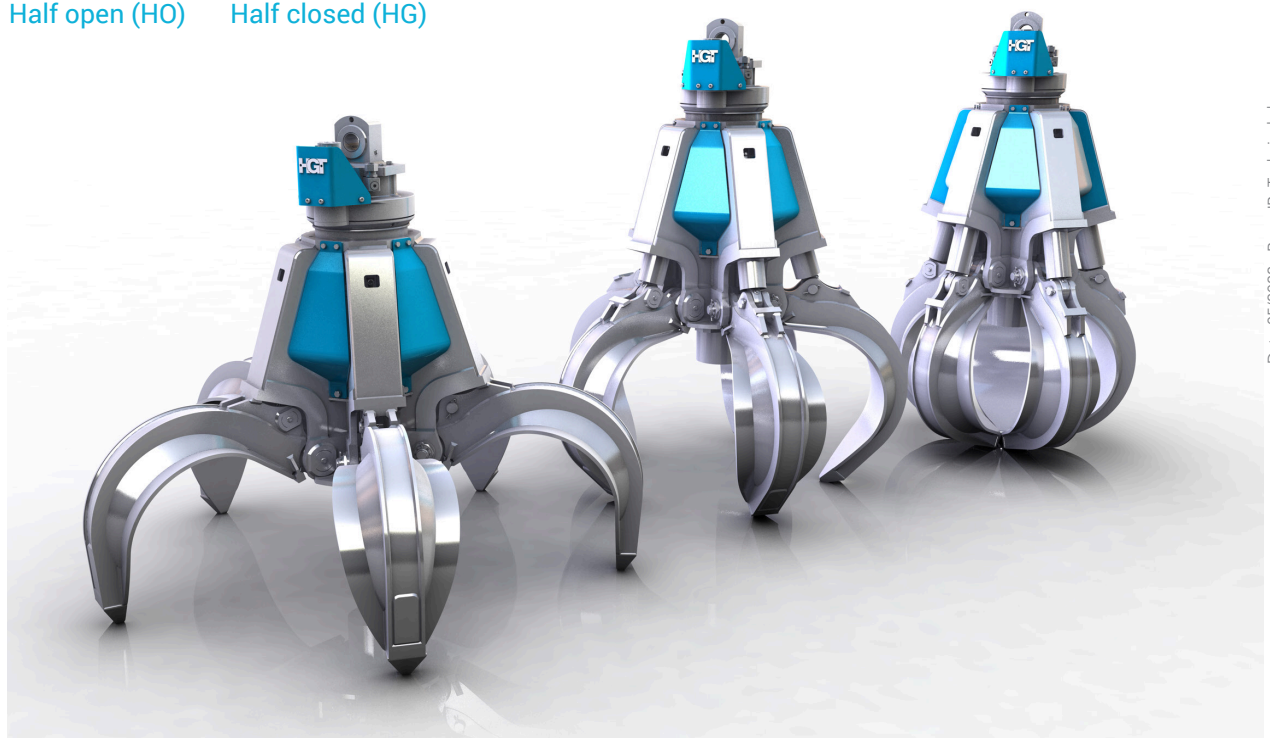

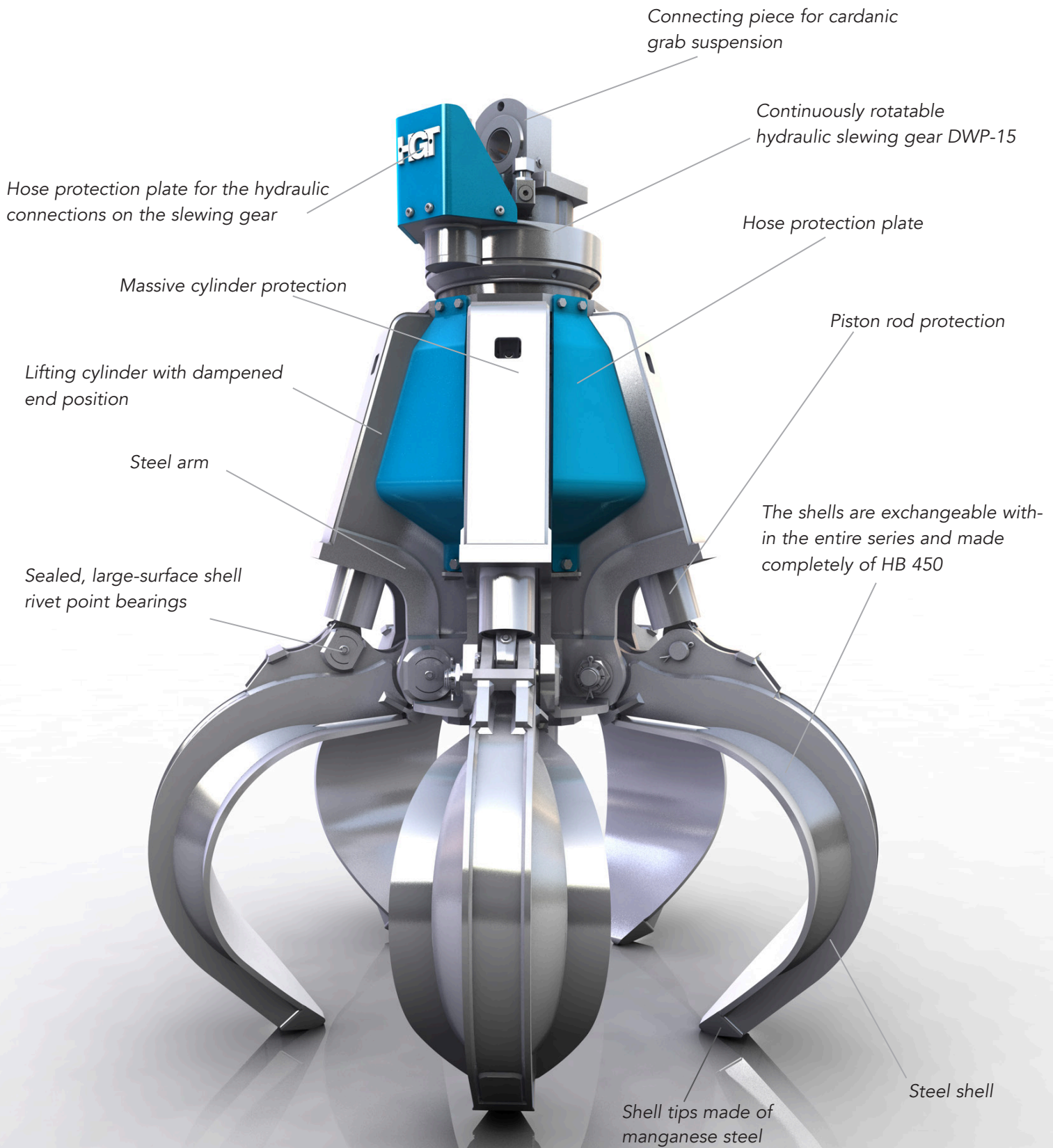

Special handling and sorting grab for large and bulky material such as found in quarries, scrap sorting, waste and recycling facilities. Available as 4 and 5 arm version.